



HiLobe®

The next generation of Roots pumps.

HiLobe®

Roots pumps for low and medium vacuum applications.



**Optimal process adaptation
through intelligent interface
technology**

Your added value

Perfectly adjustable

Roots pumps from the innovative HiLobe series offer a wide range of pumping speeds and applications. With their individual speed control, they can be adapted perfectly to customer-specific requirements. In order to operate, Roots pumps require a suitable backing pump for the application in hand, which is adjusted to the gas flow. Installation costs are reduced due to the flexible mounting position.

High performance

The superior drive concept of the HiLobe pumps can shorten pump-down times by about 20% compared to conventional Roots pumps, especially for rapid evacuations. The pumps are hermetically sealed from the atmosphere and offer a maximum integral leak rate of $1 \cdot 10^{-6}$ Pa m³/s.



**Shortest pump
down times**



**Low
operating costs**

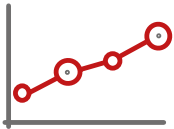

**Individually adjustable
pumping speed range**



**High
operational safety**



**No contamination of
the atmosphere,
hermetically sealed**

Low operating costs

The HiLobe series offers the lowest operating costs with the most uptime. This is achieved by using only motors with very high energy efficiency, even at different operating ranges, and optimized rotor geometries. The sealing concept makes the use of sealing gas superfluous in many cases, which reduces operating costs even more. Cost-intensive water cooling is no longer necessary due to the sophisticated air cooling concept.

Intelligent

The intelligent interface technology of the HiLobe ensures optimal adjustment and condition monitoring of processes. Intelligent condition monitoring also guarantees a long service life and maximum operational reliability.

Applications

- Electron beam welding
- Leak detection
- Metallurgy
- Coating
- Freeze drying
- Space simulation
- Vacuum packaging
- Battery production
- Vacuum drying, including transformer drying
- Insulation vacuum
- Distillation

HiLobe®

Roots pumps for low and medium vacuum applications.



Innovative drive

Innovative
Integrated and
wear-free

**Hermetically
sealed**
with integrated
motor
(IPM – interior
permanent magnet)

**Reduces
operating costs**
Execution
in high energy
efficiency class

Comparison of costs for maintenance and energy

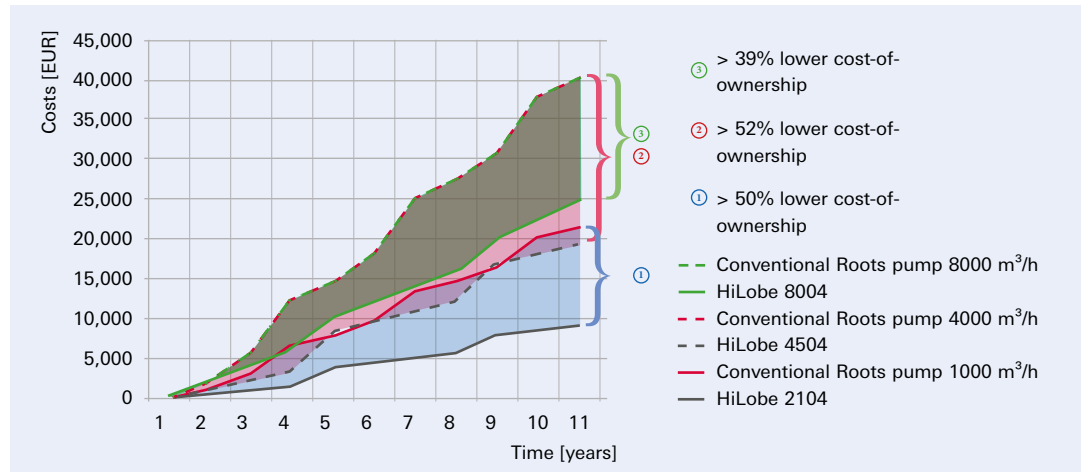

Automotive industry

We promote sustainable solutions

Energy-saving and durable

Integrating modern HiLobe Roots pumps is a sustainable and environmentally friendly way to increase the efficiency of pumping stations. In addition to a long service life and high operational reliability, these pumps feature motors that already meet the future IE4 energy efficiency class. This also applies for a variety of operational areas (such as load lock, ultimate pressure). Thus they significantly contribute to reducing operating costs and energy use in particular. Thanks to the sophisticated ventilation concept of the HiLobe, complex water cooling can also be dispensed with, thereby saving resources and reducing your operating costs.

Sustainability and social responsibility

Our CombiLine pumping stations are all optimally adapted to your process by our experts to find the most cost-effective and efficient solution for your application.

When procuring the various components and manufacturing our pumps, Pfeiffer Vacuum places the utmost importance on fair business practices, an employee-oriented human resources policy, economical use of natural resources, as well as climate and environmental protection.

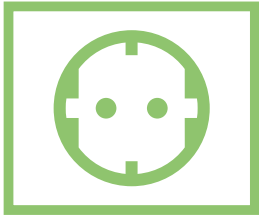

HiLobe®

Pumping speed curves, pump-down curves and dimensional drawings

Pumping speeds

HiLobe 1302/2104

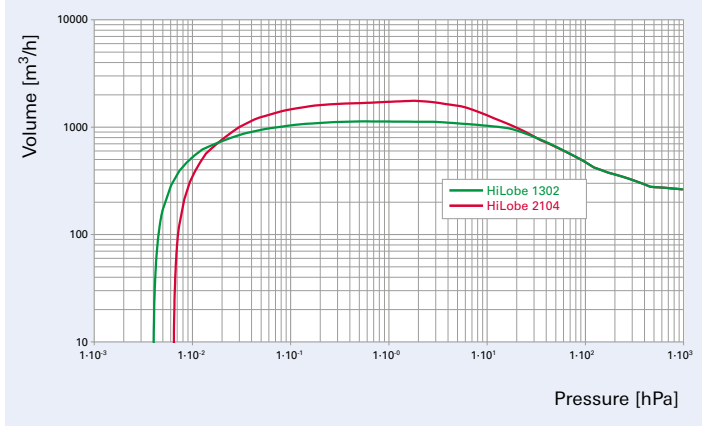

Pump-down curves

fr 750 l volume, with Hepta 300 backing pump

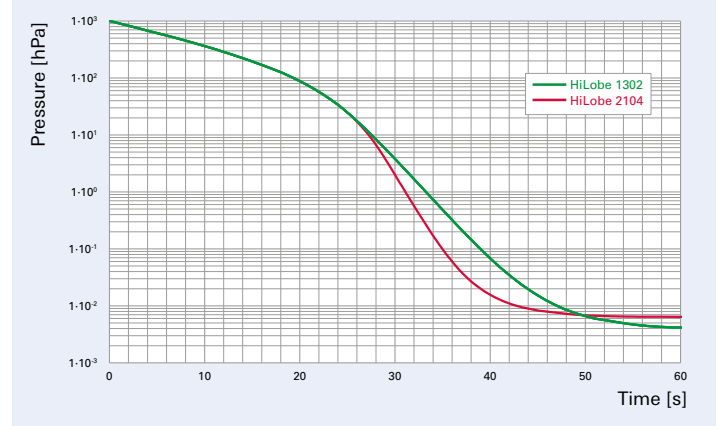

HiLobe 4504/6204

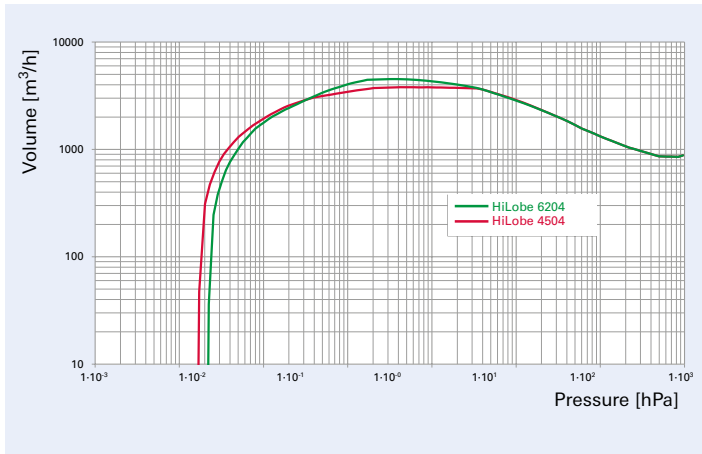

for 1800 l volume, with Hepta 950L backing pump

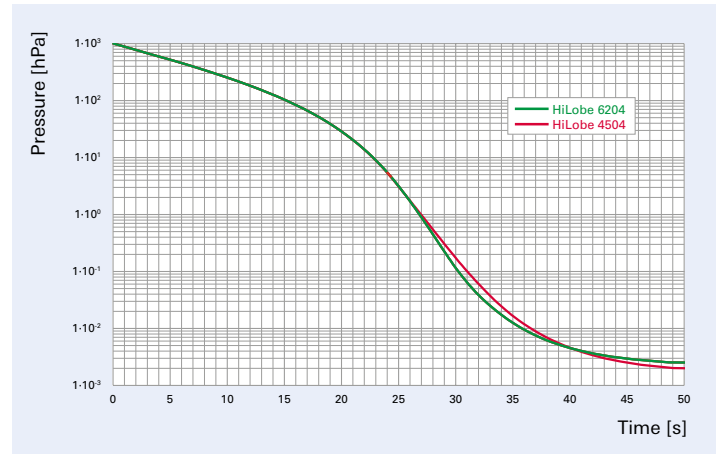

HiLobe 8104/11004

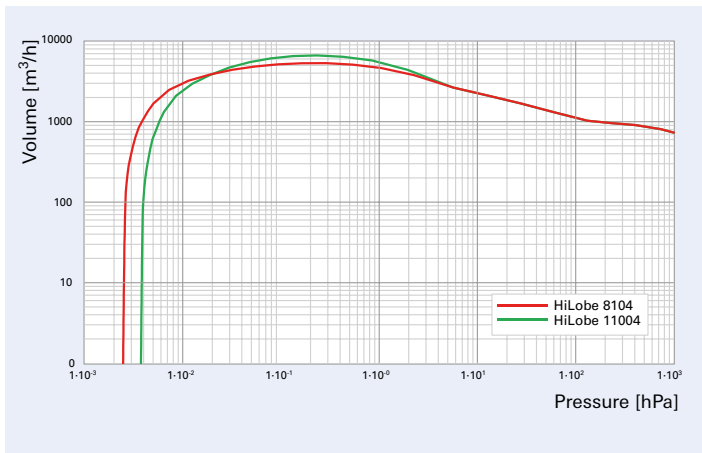

for 3000 l volume, with Hepta 950L backing pump

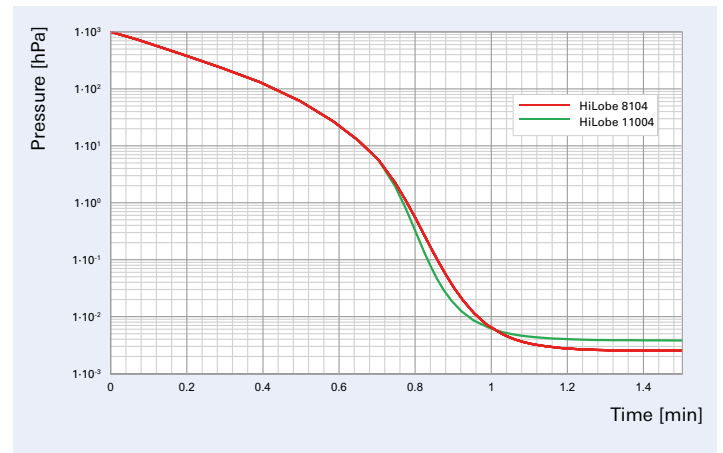

Dimensions

HiLobe 1302

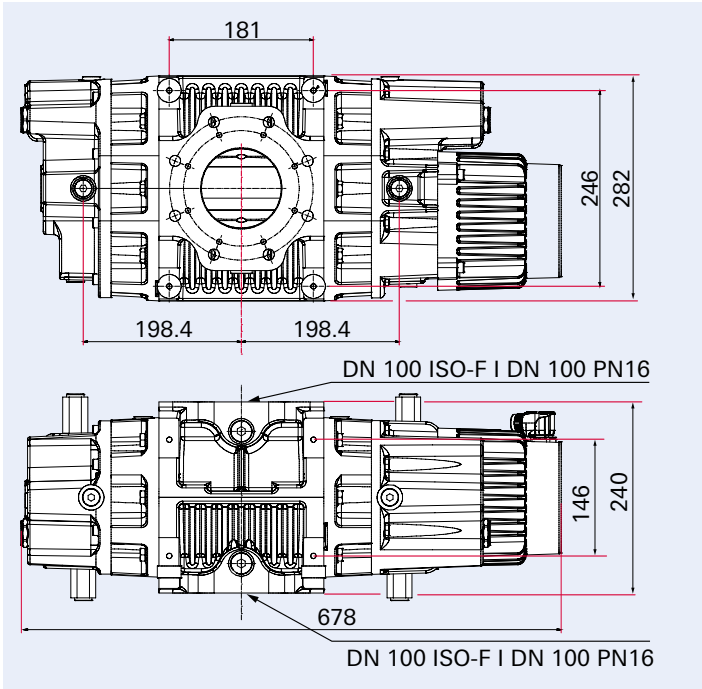

HiLobe 8103 / 11003 / 14003

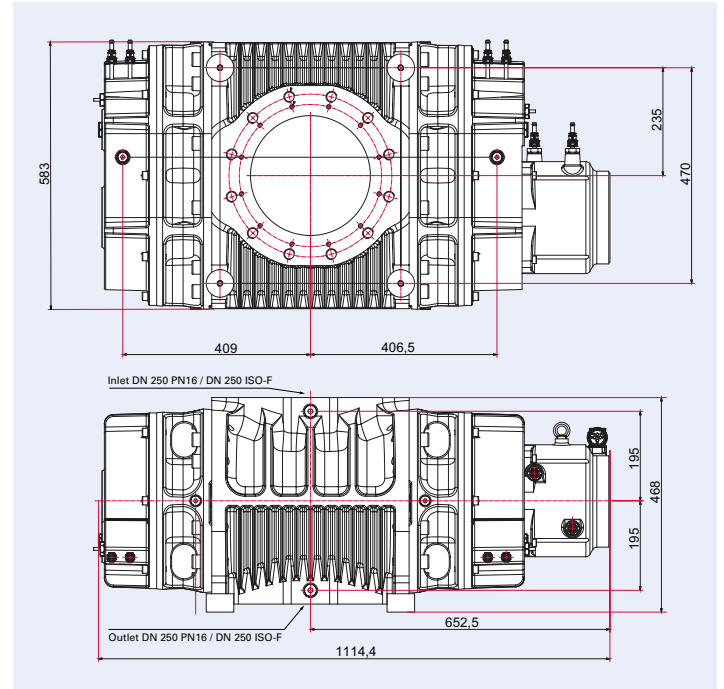

HiLobe 2104 / 4504 / 6204 / 8104 / 11004 / 14004

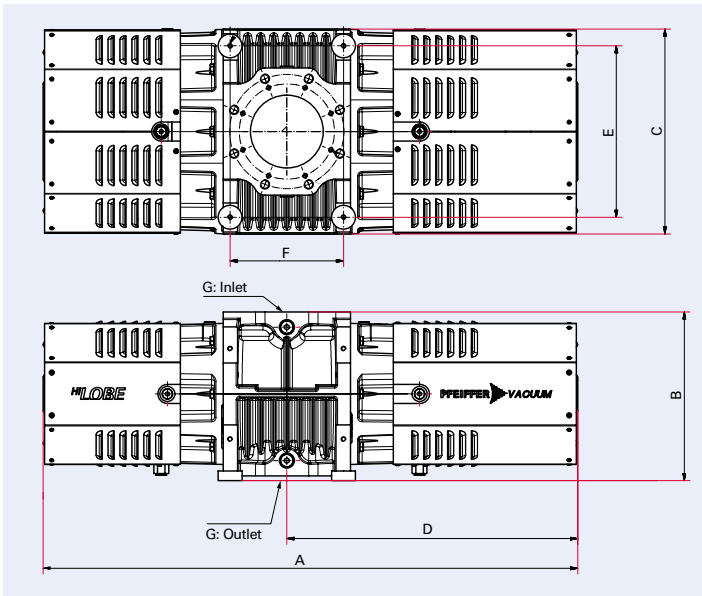

RC 5500 / RC 7500 / RC 15000

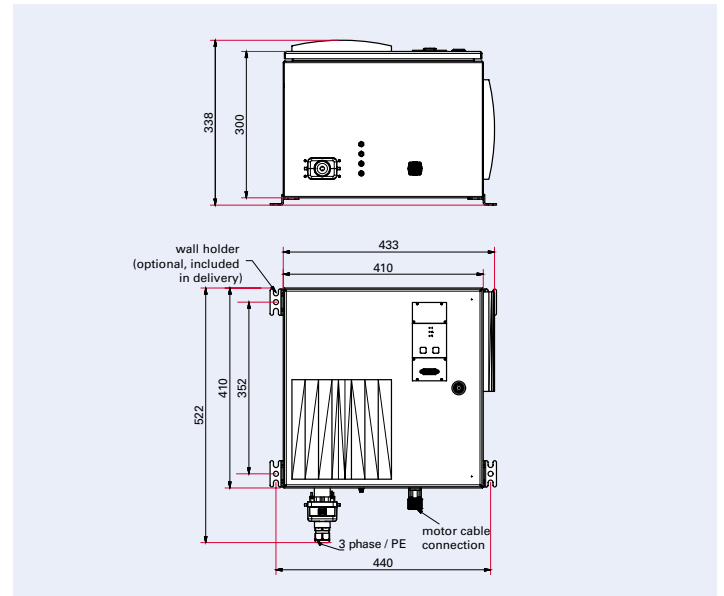

	HiLobe 2104	HiLobe 4504 / 6204	HiLobe 8104 / 11004 / 14004
A	875	1122	1433
B	283	354	468
C	251	430	583
D	499	610,5	758
E	246	360	470
F	181	238	394
G	DN 100 ISO-F / DN 100 PN16	DN 160 ISO-F / DN 150 PN16	DN 250 PN16 / DN 250 ISO-F

Dimensions in mm

Technical data

	HiLobe 1302	HiLobe 1304	HiLobe 2104	HiLobe 4504	HiLobe 6204
Flange (in)	DN 100 ISO-F I DN 100 PN16			DN 160 ISO-F I DN 150 PN16	
Flange (out)	DN 100 ISO-F I DN 100 PN16			DN 160 ISO-F I DN 150 PN16	
Mounting orientation	0° (HV flange up) 90° (HV flange at the side)				
Cooling type, standard	Air, natural convection	Air, integrated convection			
Motor protection	PTC				
Maximum differential pressure at maximum speed	13 hPa	35 hPa	12 hPa	17 hPa	10 hPa
Maximum differential pressure at minimum speed	41 hPa	75 hPa		50 hPa	
I/O interfaces	RS-485, PV.can				
Nominal pumping speed	260–1,300 m ³ /h		260–2,100 m ³ /h	890–4,440 m ³ /h	890–6,220 m ³ /h
Speed	1,500–7,500 U/min		1,500–12,000 U/min	1,500–7,500 U/min	1,500–10,500 U/min
Integral leak rate	< 1 · 10 ⁻⁵ hPa l/s				
Emission sound pressure level (EN ISO 2151) at intake pressure 1 hPa and nominal speed	60 dB(A)	68 dB(A)	69 dB(A)	65 dB(A)	
Operating voltage/frequency	3~ 380-480 V AC +/-10% 50/60 Hz				
Nominal power at maximum speed	2.5 kW	2.5 kW	3.5 kW	5.5 kW	7.5 kW
Operating fluids	D1				
Operating fluid quantity	0.65 l		3.2 l		
Dimensions (L x W x H)	678 x 282 x 240 mm	875 x 282 x 240 mm		1.112 x 430 x 354 mm	
Protection class	IP54				
Ambient temperature	5–40 °C				
Weight	105 kg	115 kg		280 kg	

Size and mounting options

HiLobe 1302
with convection cooling,
separate frequency converter
and connection cable

HiLobe 2104
with integrated air cooling,
frequency converter and
connection cable

HiLobe 4504/6204
with air cooling,
separate frequency converter
and connection cable

Vertically mounted



Horizontally mounted



HiLobe 8103	HiLobe 11003	HiLobe 14003	HiLobe 8104	HiLobe 11004	HiLobe 14004
DN 250 ISO-F DN 250 PN16					
DN 250 ISO-F DN 250 PN16					
0° (HV flange up)					
Water cooling			Air, integrated convection		
PTC					
25 hPa	20 hPa	10 hPa	25 hPa	20 hPa	10 hPa
30 hPa			30 hPa		
RS-485, PV.can					
2,700 m ³ /h – 8,100 m ³ /h	2,700 m ³ /h – 10,800 m ³ /h	2,700 m ³ /h – 13,600 m ³ /h	2,700 m ³ /h – 8,100 m ³ /h	2,700 m ³ /h – 10,800 m ³ /h	2,700 m ³ /h – 13,600 m ³ /h
1,500–4,500 U/min	1,500–6,000 U/min	1,500–7,500 U/min	1,500–4,500 U/min	1,500–6,000 U/min	1,500–7,500 U/min
< 1 · 10 ⁻⁵ hPa l/s					
70 dB (A)			75 dB (A)		
3~ 380-480 V AC +/-10% 50/60 Hz					
9 kW	12 kW	15 kW	9 kW	12 kW	15 kW
D1					
3.0 l			5.2 l		
1.115 x 583 x 468 mm			1.433 x 583 x 468 mm		
IP54					
5–40 °C					
620 kg			670 kg		

HiLobe 14004
13,600 m³/h
Nominal pumping speed

15 kW

Nominal power at maximum speed



HiLobe 8103 / 11003 / 14003
with integrated water cooling,
separate frequency converter
and connection cable



HiLobe 8104 / 11004 / 14004
with air cooling,
separate frequency converter
and connection cable



Comparison of versions

	Integrated water cooling	Integrated active air cooling	Convection cooling	Frequency converter and connection cable included in delivery	Pumping speeds
HiLobe 1302			■	■	up to 1,300 m ³ /h
HiLobe 2104		■		■	up to 2,100 m ³ /h
HiLobe 4504/6204		■		■	up to 6,200 m ³ /h
HiLobe 8103/11003/14003	■			■	up to 13,600 m ³ /h
HiLobe 8104/11004/14004		■		■	up to 13,600 m ³ /h

Accessories and order number matrix

Accessories

General accessories	Order number
Controller/cable	
HPU 001, Handheld Programming Unit	PM 051 510 -T
RJ 45 interface cable on M12	PM 051 726 -T
Accessories package for HPU	PM 061 005 -T
USB RS-485 converter	PM 061 207 -T
Interface cable, M12 m straight/M12 m straight	PM 061 283 -T
Interface cable, M12 m straight/M12 m angled	PM 061 791 -T
DCU 002, Display Control Unit	PM 061 348 AT
TCS 11, adapter for TC 110/120	PM 061 636 -U
Extension cable package 3 m	PP 100 304 -T
Extension cable package 5 m	PP 100 306 -T
Extension cable package 10 m	PP 100 311 -T
Converter package ProfiNet	PE 300 301 -T
Converter package EtherCat	PE 300 311 -T
Process accessories	
Sealing Gas Kit (Plastic Tube)	PP 100 091 -T
Gear Box Evacuation (Plastic Tube)	PP 100 092 -T
Operating fluids	
P3, mineral oil, 0,5 l	PK 001 136 -T
P3, mineral oil, 1 l	PK 001 106 -T
P3, mineral oil, 5 l	PK 001 107 -T
P3, mineral oil, 20 l	PK 001 108 -T
D1, 1 l	PK 005 875 -T
D1, 5 l	PK 005 876 -T
D1, 20 l	PK 005 877 -T
F5, 0,5 l	PK 001 851 -T
F5, 1 l	PK 001 852 -T
F5, 5 l	PK 001 853 -T

Accessories for HiLobe 1302 – 2104	Order number
Components/Seals	
Centering ring with splinter shield, DN 100 ISO	PM 016 211 AU
Splinter shield, DN 100 PN16	PP 042 350 -X

Process accessories	Order number
Spray lance G1/2"	PP 042 765 -U
Temperature sensor, PT100	PP 100 090 -T

Accessories for HiLobe 4504 – 6204	Order number
Components/Seals	
Centering ring with splinter shield, DN 160 ISO	PM 016 217 AU
Splinter shield, DN 150 PN16	PP 031 115 -X

Process accessories	Order number
Spray lance G1/2"	PP 042 765 -U
Temperature sensor, PT100	PP 200 090 -T

Accessories for HiLobe 8103 – 14004	Order number
Components/Seals	
Centering ring with splinter shield, DN 250 ISO	PM 016 226 AU
Splinter shield, DN 250 PN16	PP 031 137 -X

Process accessories	Order number
Spray lance G1/2"	PP 046 146 -U
Temperature sensor, PT100	PP 300 090 -T



Electron beam welding



Steel degassing

Order number matrix
HiLobe

Order number
PP Vab cde

Size and direction of flow	a
HiLobe 1302 – 2104 – Vertical	2
HiLobe 1302 – 2104 – Horizontal	3
HiLobe 4504 – 6204 – Vertical	4
HiLobe 4504 – 6204 – Horizontal	5
HiLobe 8103 – 14004 – Vertical	6

Maximum pumping speed m³/h	b
HiLobe 8103/8104 = 8,100 m ³ /h	0
HiLobe 1302 = 1,300 m ³ /h HiLobe 4504 = 4,500 m ³ /h HiLobe 11003/11004 = 11,000 m ³ /h	1
HiLobe 2104 = 2,100 m ³ /h HiLobe 6204 = 6,200 m ³ /h HiLobe 14003/14004 = 13,600 m ³ /h	2

Cooling¹⁾	c
Convection cooling ²⁾	2
Integrated water cooling ⁴⁾	3
Integrated air cooling	4

Electronic drive unit	d
RC (Roots Control), 305-528 V, 50/60Hz	0
RC (Roots Control), 180-260 V, 50/60Hz	2

Operating fluids	e
P3	0
D1	1
F5 ³⁾	2

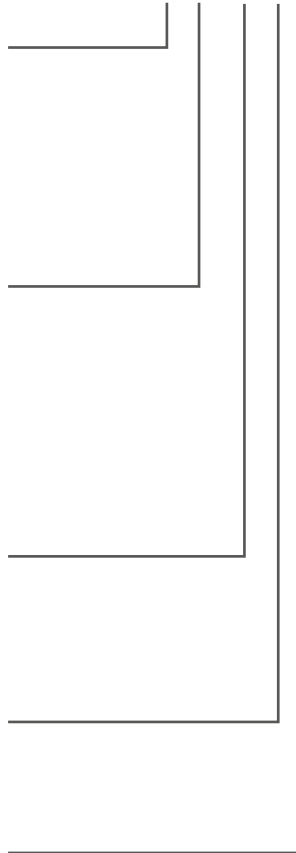

1) Alternative version on request
 2) Only for HiLobe 1302
 3) Only for HiLobe 8103–14004
 4) Only for HiLobe 8103–14003

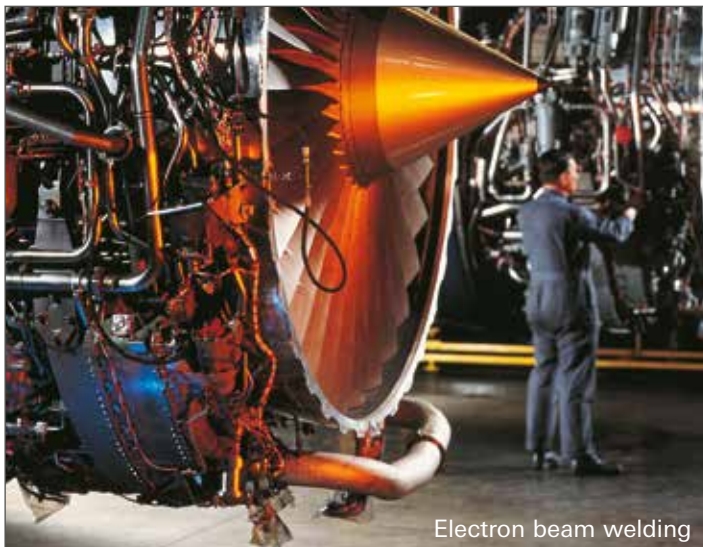

Electron beam welding



Coating

Your Success. Our Passion.

We give our best for you every day –
worldwide!

Are you looking for your
optimized vacuum solution?
Please contact us:

Pfeiffer Vacuum GmbH
Germany
T +49 6441 802-0



All information is subject to change without prior notice. PW 0039 PEN (March 2022/PoD)

Follow us on social media
#pfeiffervacuum



www.pfeiffer-vacuum.com

PFEIFFER  **VACUUM**