

HIGH PERFORMANCE – MOBILE – ASM 380

Mobile unit optimized for rapid pump down and short response times on large test objects

Dry and mobile

Our ASM 380 high-performance leak detector is fitted with an ACP 40 dry backing pump combined with a powerful high vacuum pump. This makes it the ideal solution for maximum testing sensitivity in analytics, laboratories, the solar panel industry and the semiconductor industry. With the ASM 380, you will achieve extremely short pump down times even where large volumes are involved. The slim design and compact size set up on a cart with large wheels and a low center of gravity make this leak detector mobile and safe to handle.

User-friendly

The ASM 380 with its low noise level of only 53 dB(A) is unusually quiet for a leak detector of its class. The color display panel with full 360° viewing can be read from any position. This display is also detachable and can be positioned where the user can see it using four strong magnetic clips. An integrated SD memory card makes it easy to save test data and settings parameters. The ASM 380 has an integrated lockable toolbox for tools, spare parts and accessories. Thanks to its convenient bottle-holder, it is even possible to attach and carry a tracer gas bottle.

Compatible

The ASM 380 can likewise be operated with the wireless remote control RC 500 WL. This enables the leak detector to be operated even from a distance of up to 100 meters.



Remote control RC 500 WL

Customer benefits

- Performance, sensitivity and mobility in the smallest footprint
- High roughing capacity using particle-free, clean and dry ACP pump
- Clean room compatible
- High crossover pressure for a rapid entry into measurement mode
- Optional communication interfaces
- Color touch display with full 360° viewing offering excellent visibility
- Intuitive menus, easy to navigate and available in 9 languages



Applications

- Semiconductor industry
- Large area coating
- Solar industry
- Accelerators
- Vacuum components – feedthroughs, valves, bellows, expansion joints
- Laser technology
- Ultra-pure media supply
- Electronics
- Aeronautics
- Medical technology

HIGH PERFORMANCE – MOBILE – ASM 380

Mobile unit optimized for rapid pump down and short response times on large test objects

Dimensions

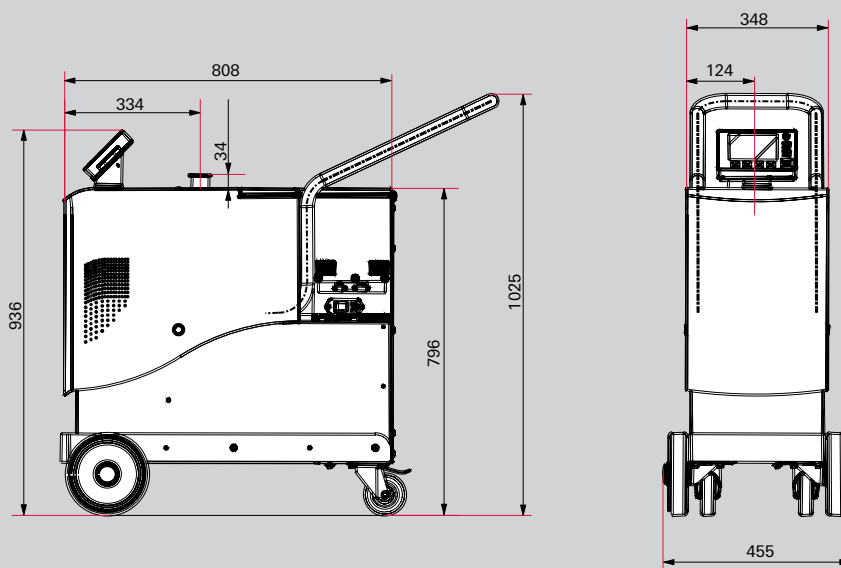

Dimensions in mm

Technical data

	ASM 380
Flange (in)	DN 40 ISO-KF
Test methods	Vacuum and sniffing leak detection
Detectable gases	^4He , ^3He , H_2
Minimum detectable leak rate for He (sniffer leak detection)	$1 \cdot 10^{-9} \text{ Pa m}^3/\text{s}$
Minimum detectable leak rate for He (vacuum leak detection)	$5 \cdot 10^{-13} \text{ Pa m}^3/\text{s}$
Pumping speed for He	7 l/s
Noise level	53 dB (A)
Supply	90–240 V; 50/60 Hz
Power consumption max.	1,500 W
Power consumption	700 W
Maximum inlet test pressure	15 hPa
Start-up time (20 °C) without calibration	< 4.5 min
Start-up time (20 °C) with calibration	< 5.5 min
I/O interfaces	1 digital input (start cycle); 2 digital outputs (test mode ok, helium signal above reject setpoint); 3 analog outputs (configurable: helium signal log, mantissa, exponent, inlet pressure)
Interface	RS-232
Operating temperature	10–35 °C
Backing capacity	35 m ³ /h
Weight	110 kg

Order numbers

Leak detector	Order number
ASM 380, universal voltage	PSGB00E0MM9A
ASM 380, universal voltage, integrated Bluetooth	PSGB00E1MM9A
ASM 380, universal voltage, configurable I/O interface board	PSGB00E2MM9A
ASM 380, universal voltage, configurable I/O interface board, integrated WiFi	PSGB00E3MM9A
ASM 380, universal voltage, configurable I/O interface board, Ethernet	PSGB00E4MM9A
ASM 380, universal voltage, configurable I/O interface board, integrated Bluetooth	PSGB00E5MM9A

Order numbers for accessories

Accessories	Order number
Bottle holder for ASM 380	118444
Inlet filter, 20 µm, DN 40/40 ISO-KF	105842
Remote control RC 500 WL, wireless	PT 445 432-T
Locking clamp, DN 40 KF	118801

General accessories for our leak detectors can be found on page 46.