

HiPace™ 10

Small and robust turbopump with a pumping speed of 10 l/s for N₂



- ▶ The small design makes for minimum footprint
- ▶ Integrated drive electronics, suitable for industrial environments - Protection class IP 54
- ▶ Semi S2- and UL/CSA certification
- ▶ Maximum reliability through monitoring of operating data

Pumping speed

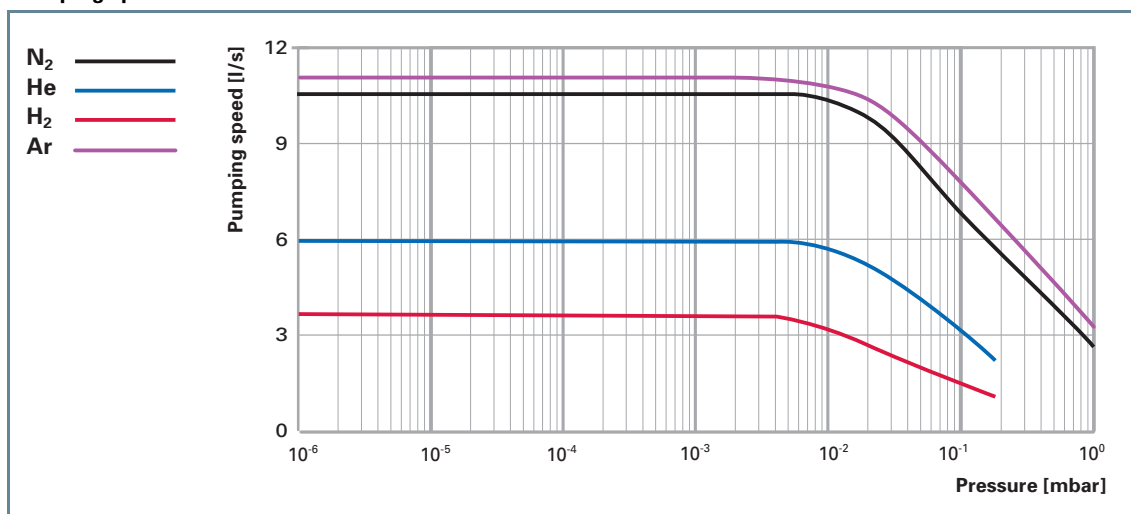

HiPace™ 10

Dimensions

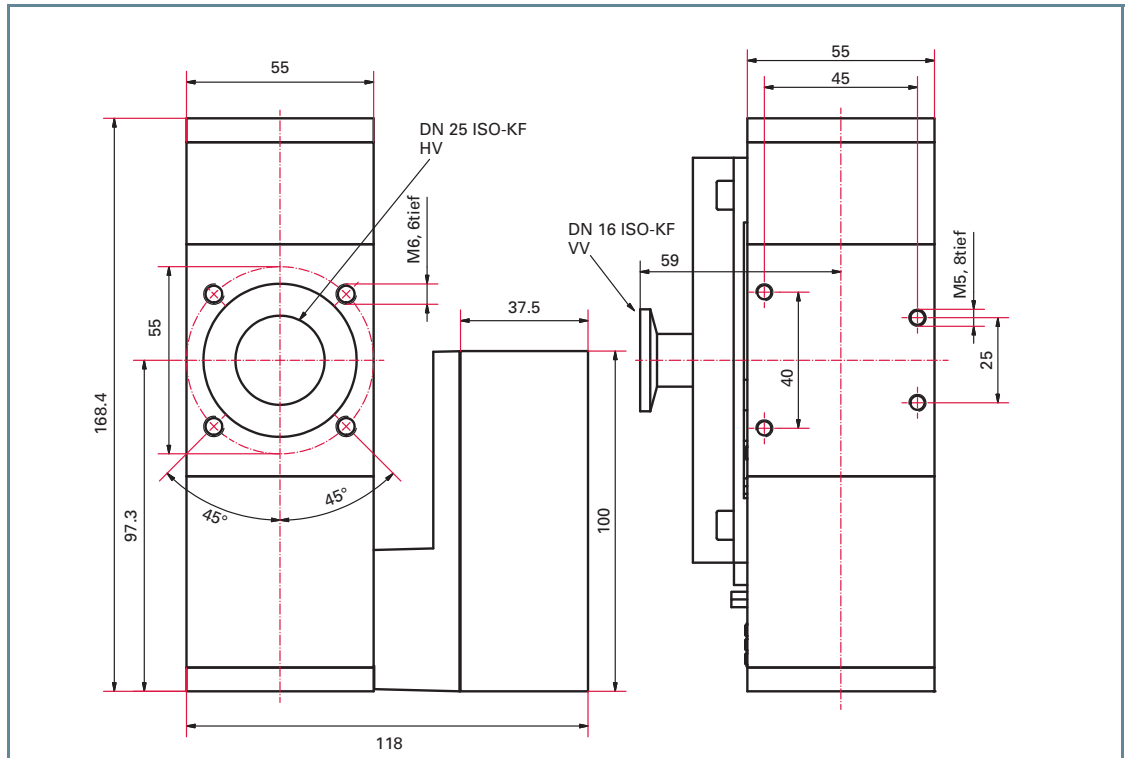

HiPace™ 10, with TC 110, DN 25

Technical data	HiPace™ 10, with TC 110, DN 25
Connection nominal diameter	
Flange (in)	DN 25
Flange (out)	DN 16 ISO-KF
Pumping speed	
Pumping speed for H ₂	3.7 l/s
Pumping speed for He	6 l/s
Pumping speed for N ₂	10 l/s
Pumping speed for Ar	11.5 l/s
Compression	
Compression ratio for H ₂	3·10 ²
Compression ratio for He	3·10 ³
Compression ratio for N ₂	3·10 ⁶
Compression ratio for Ar	3·10 ⁷
Fore Vacuum max. for N₂	25 mbar
Gas throughput	
Gas throughput at full rotational speed for H ₂	0.15 mbar l/s
Gas throughput at full rotational speed for He	0.15 mbar l/s
Gas throughput at full rotational speed for N ₂	0.15 mbar l/s
Gas throughput at full rotational speed for Ar	0.15 mbar l/s
Ultimate pressure	< 5·10 ⁻⁵ mbar
Rotation speed ±2%	90000 rpm
Run-up time	0.9 min
Cooling method, standard	Convection cooling
Permissible magnetic field max.	3 mT
Sound pressure level	< 45 dB (A)
Protection category	IP 54
Interfaces	RS-485, Remote
Weight	1.8 kg
Order number pump	PM P03 960

Accessories	HiPace™ 10, with TC 110, DN 25
Order number pump	PM P03 960
Power supplies/power	
DCU - power supply with display control unit	PM C01 820
TPS - mains pack for wall/standard rail fitting	PM 061 340-T
TPS - mains pack 19" rack module 3 RU	PM 061 344-T
Control units	
DCU - Display Control Unit	PM 061 348-T
HPU - Handheld Programming Unit	PM 051 510-T
Accessories for HPU	PM 061 005-T
Mains cable DCU/TPS/TCP, 3 m	
230 V AC mains cable with Euro-style safety plug	P 4564 309 ZA
115 V AC mains cable with UL plug	P 4564 309 ZE
208 V AC mains cable with UL plug	P 4564 309 ZF
Connection cable, length 3 m between	
TC 110 / TPS/DCU 110/111/180/181 with accessory ports und RS-485,	PM 061 351-T
Connection cable for HiPace with TC 110 to power supply TPS/DCU 110/111/180/181 with bridges and RS-485	PM 061 350-T
Backing pump control	
Backing pump relay box, single phase 5 A	PM 061 372-T
Backing pump relay box, single phase 20 A	PM 061 373-T
TVV 001 backing vacuum safety valve, 230 V AC	PM Z01 205
TVV 001 backing vacuum safety valve, 115 V AC	PM Z01 206
General accessories	
Connecting adapter DN 25 ISO-KF	PM 093 315-T
Centering ring	PF 110 125-T
Centering ring, with integrated mesh screen	PF 113 225-T
USB converter	PM 061 207-T
Interface cable, 3 m, M 12	PM 061 283-T
Y-connector, M12, for RS-485	P 4723 010
Mounting materials	
Centering ring with 4 prackets, screws and U-washers	PM 016 627-T